

GENERAL NOTES:

FASTEN ASSEMBLY TO A 6mm STEEL PLATE BY FOUR M10X40mm LG HEX HD BOLTS, NUTS, AND LOCK WASHERS.

ROUNDS AND FILLETS R3

FIT	BETWEEN PARTS
H8/f7	4 AND 5
H7/p6	3 AND 5
H8/f7	2 AND 4

PARTS LIST

ITEM	QTY.	PART NAME	MATERIAL
1	1	TOP PLATE	MALLEABLE IRON
2	1	WHEEL	MALLEABLE IRON
3	2	AXLE SUPPORT	MALLEABLE IRON
4	1	AXLE	1020 STEEL
5	2	BUSHING	BRONZE

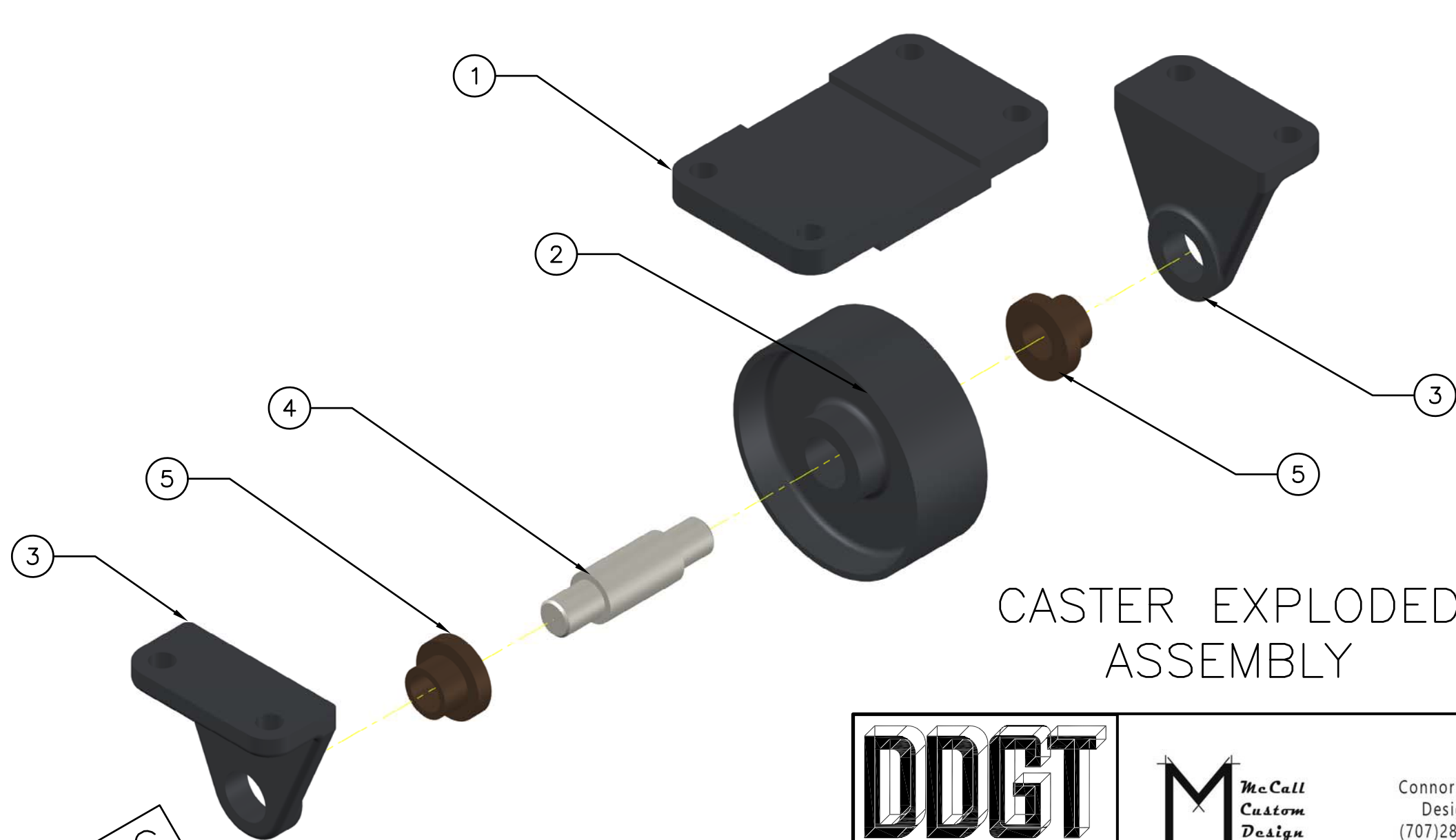

CASTER ASSEMBLY

CASTER EXPLODED ASSEMBLY

LEGEND:

- ° DEGREES
- ∅ DIAMETER
- R RADIUS
- ⌊ SPOTFACE

METRIC

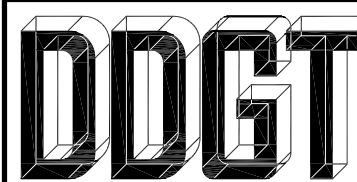

DIGITAL DESIGN
GRAPHICS
TECHNOLOGY

WWW.DDGT.NET



Connor McCall
Designer
(707)287-6180
connorm.1440@gmail.com

www.ddgt.net/cmccall

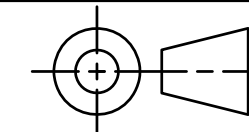

TOLERANCES UNLESS SPECIFIED:
MILLIMETERS:
WHOLE NUMBERS = ±0.5
X = ±0.25
XX = ±0.12
ANGLES ±1 DEGREE
SURFACES 32/√

COURSE: DDGT 120

AUTOCAD DRAWING NAME:
CASTER

FIG #: 9- 51

DRAFTER: C. MCCALL

DATE: 10/25/2018

SCALE: 1:2

PAGE #: 1 OF 3

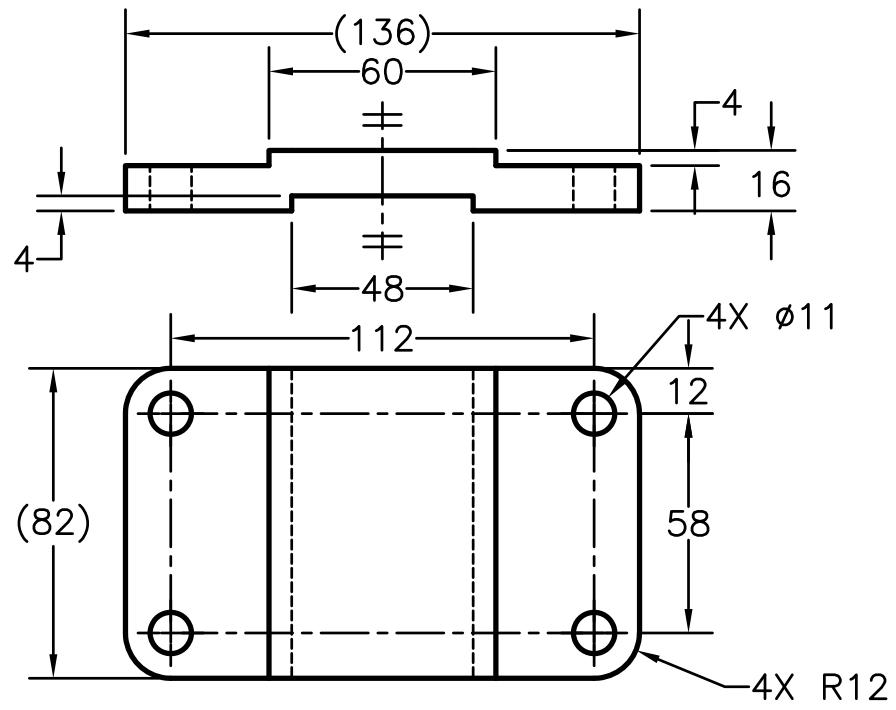

TOP PLATE

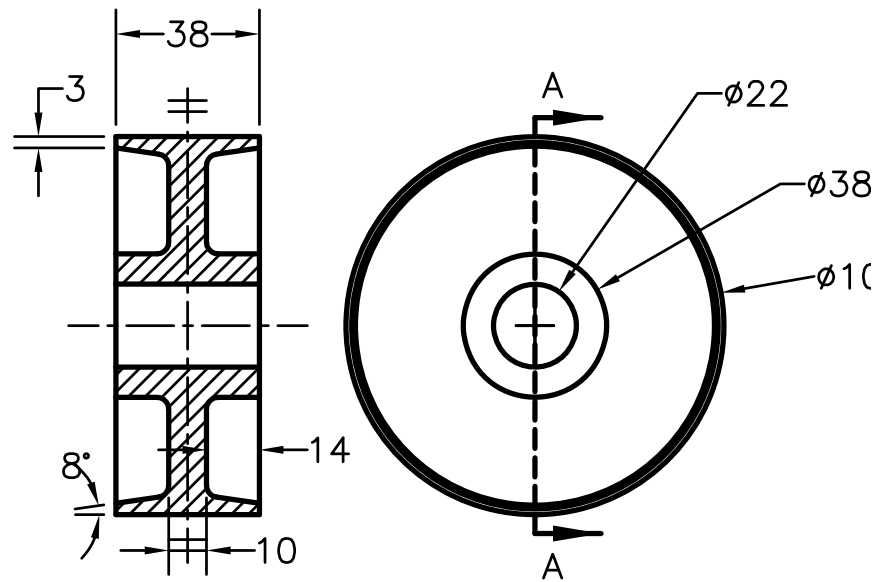
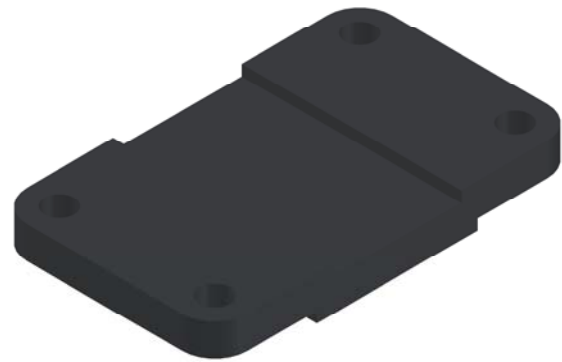

SECTION A-A
WHEEL

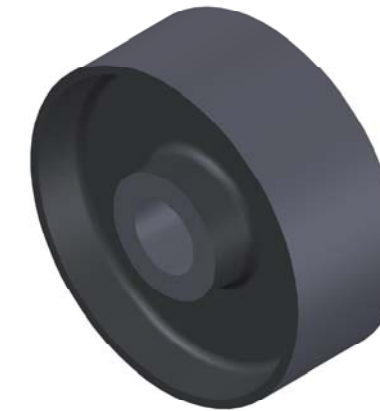

PARTS LIST

ITEM	QTY.	PART NAME
1	1	TOP PLATE
2	1	WHEEL

LEGEND:

- ° DEGREES
- Ø DIAMETER
- R RADIUS
- ⌊ SPOTFACE

METRIC

GENERAL NOTES:

FASTEN ASSEMBLY TO A 6mm STEEL PLATE BY FOUR M10X40mm LG HEX HD BOLTS, NUTS, AND LOCK WASHERS.

ROUNDS AND FILLETS R3

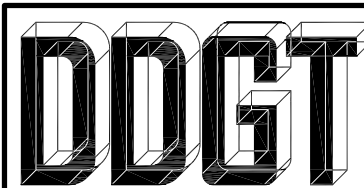

DIGITAL DESIGN
GRAPHICS
TECHNOLOGY

WWW.DDGT.NET



Connor McCall
Designer
(707)287-6180
connorm.1440@gmail.com

www.ddgt.net/cmccall

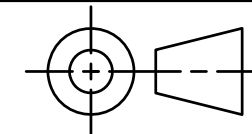

TOLERANCES UNLESS SPECIFIED:
MILLIMETERS:
WHOLE NUMBERS = ±0.5
X = ±0.25
XX = ±0.12

ANGLES ±1 DEGREE

SURFACES 32/

COURSE: DDGT 120

AUTOCAD DRAWING NAME:
CASTER

FIG #: 9- 51

DRAFTER: C. MCCALL

DATE: 10/25/2018

SCALE: 1:2

PAGE #: 2 OF 3

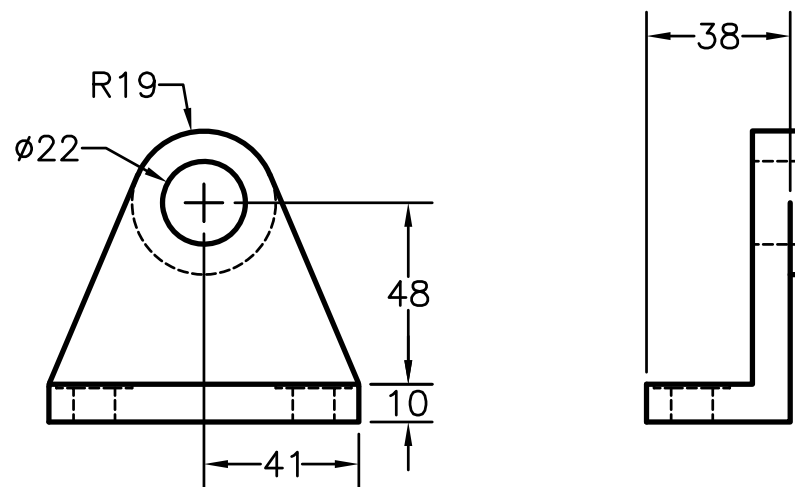
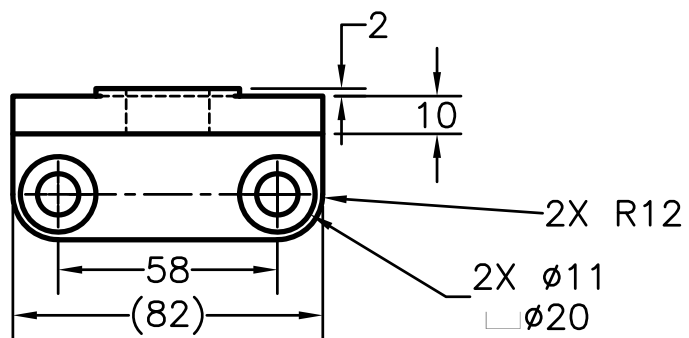

AXLE SUPPORT

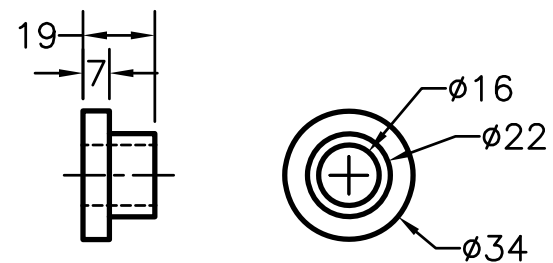
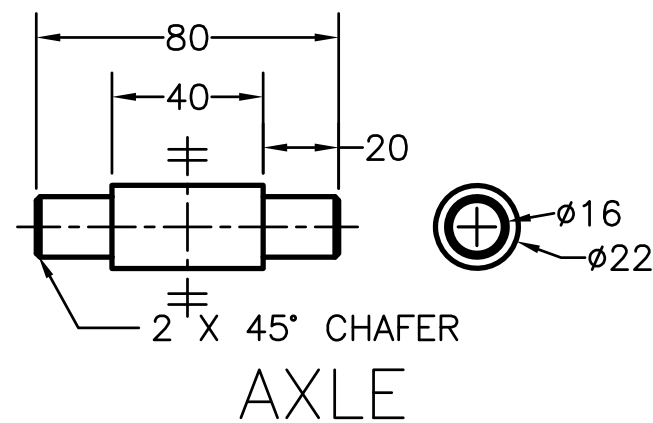

BUSHING

PARTS LIST

ITEM	QTY.	PART NAME
3	2	AXLE SUPPORT
4	1	AXLE
5	2	BUSHING

LEGEND:

- ° DEGREES
- ø DIAMETER
- R RADIUS
- ┌ SPOTFACE

METRIC

GENERAL NOTES:

FASTEN ASSEMBLY TO A 6mm STEEL PLATE BY FOUR M10X40mm LG HEX HD BOLTS, NUTS, AND LOCK WASHERS.

ROUNDS AND FILLETS R3

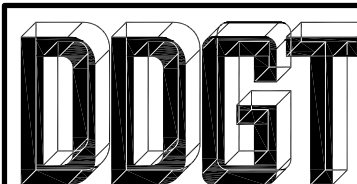

DIGITAL DESIGN
GRAPHICS
TECHNOLOGY

WWW.DDGT.NET



Connor McCall
Designer
(707)287-6180
connorm.1440@gmail.com

www.ddgt.net/cmccall

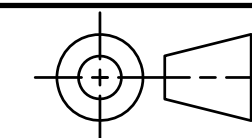

TOLERANCES UNLESS SPECIFIED:
MILLIMETERS:
WHOLE NUMBERS = ±0.5
X = ±0.25
XX = ±0.12
ANGLES ±1 DEGREE
SURFACES 32/

COURSE: DDGT 120

AUTOCAD DRAWING NAME:
CASTER

FIG #: 9- 51

DRAFTER: C. MCCALL

DATE: 10/25/2018

SCALE: 1:2

PAGE #: 3 OF 3